





EGR North America
4000 East Greystone Drive
Ontario, CA 91761

Phone: +(909) 923 7075 Fax: (909) 923 0945
Email: info@egrusa.com

© Copyright 2017 / Patent Pending
Oakmoore Pty Ltd trading as EGR.

1. EGR expressly disclaims any representations or warranties of any kind, whether express or implied, as to the accuracy, currency, completeness and/or the merchantability or fitness for a particular purpose of any information contained in or provided via this documentation and/or any service or product described or promoted in this document. 2. It is the customer's responsibility to thoroughly examine StyleLite by a qualified person, to determine whether it is suitable for the application it was purchased for. 3. The receiver of our products is fully responsible to check and to take into account possible third party's patent rights, as well as the existing laws in the country of installation prior to installing our product. 4. No liability may be derived from these images or statements nor from our free technical advice. 5. EGR reserves the right to change, add or remove colors or product without notice. 6. StyleLite is for indoor use only. 7. StyleLite and EGR are registered trademarks. 8. Images and colors should be used as a guide only.

StyleLite®

Thank you for your interest in the StyleLite® product range.

This document provides a comprehensive set of technical specifications for StyleLite, as well as answering common questions about machining, fabrication, installation and care.

For further enquiries visit **www.stylelite.net** or contact your nearest StyleLite distributor.

Contents

StyleLite Product Range	2
Edge Finishing	4
Hinge Recommendations	4
Important Warning	5
Things to Consider	5
Storage and Handling	5
Machining Guide	6
Cleaning Do's and Don'ts	7
Scratch Repair	7
StyleLite Sheet Lamination Guide	8
Environmental Statement	9
StyleLite 10 Year Indoor Warranty	10
StyleLite Product Specifications	12

Introduction

All StyleLite panels feature StyleLite Sheet laminated front and back to a quality substrate. Our Product Range is divided into various applications, based on the best use of each substrate.

StyleLite is available in two finish options – **High Gloss**, or **Velvet (matte)**.

Finish Options

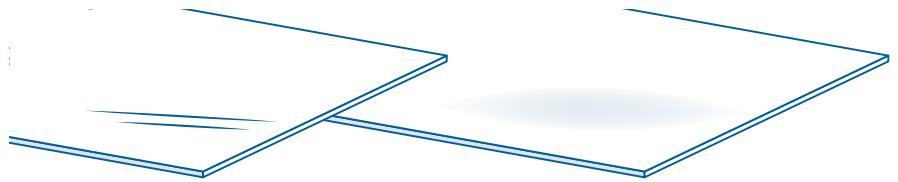

High Gloss

Smooth, ultra gloss finish that provides a mirror-like appearance. Highly reflective.

Velvet

Smooth, untextured matte finish, that provides increased scratch resistance over High Gloss.

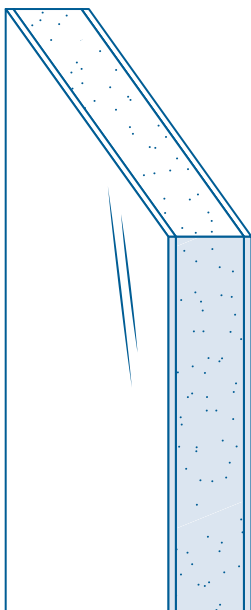

StyleLite Standard Panels

Regular StyleLite panels, suitable for a range of general purpose applications. Uses premium quality moisture-resistant MDF, rated to formaldehyde emissions standard E0. Perfect for kitchen and vanity doors and panels, furniture, hinged wardrobe doors, and general cabinetry.

Substrate	Finished Panel Size	Region	Weight	Finish
MR MDF E0	2400 × 1200 × 18mm	Global	13.5kg/m ²	High Gloss and Velvet
MR MDF E0	3000 × 1200 × 18mm	Australasia	13.5kg/m ²	High Gloss
MR MDF CARB 2	97" × 48.5" × 3/4"	North America	2.76lb/ft ²	High Gloss
MR MDF E0	2700 × 1200 × 34mm	New Zealand	25kg/m ²	High Gloss
MR MDF E0	2700 × 1200 × 18mm	New Zealand South Africa	13.5kg/m ²	High Gloss

Other Substrates available on request. Optional White Textured Backing Sheet also available on all products except MR MDF E0 3000 x 1200 x 18mm.

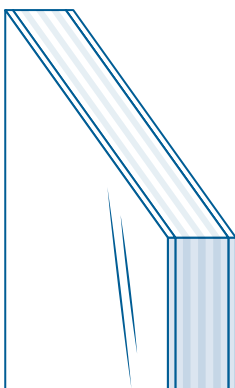

StyleLite Lightweight Panels

Lightweight panels, perfect for when weight is a consideration. Uses high quality lightweight plywood. Great for interior fitout for caravans and RVs – from furniture and kitchen cabinetry, to vanity doors and panels.

Substrate	Finished Panel Size	Region	Weight	Finish
Lightweight Plywood	2400 × 1200 × 14mm	Global	7kg/m ²	High Gloss and Velvet
Lightweight Plywood	2400 × 1200 × 17mm	Global	8kg/m ²	High Gloss and Velvet
Lightweight Plywood CARB 2	96" × 48" × 11/16"	USA	1.43lb/ft ²	High Gloss and Velvet

Optional White Textured Backing Sheet also available.

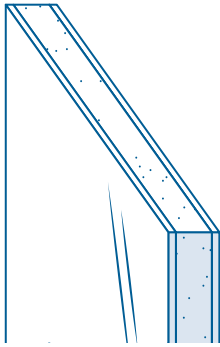

StyleLite Wardrobe Panels

Ultra-thin lightweight panels, created specifically for sliding wardrobe door applications. The MDF substrate provides rigidity while remaining easy to work, while the thin panel thickness ensures compatibility with most wardrobe rail systems.

Substrate	Finished Panel Size	Region	Weight	Finish
MDF	2400 × 1200 × 9.5mm	Global	8kg/m ²	High Gloss

Optional White Textured Backing Sheet also available.

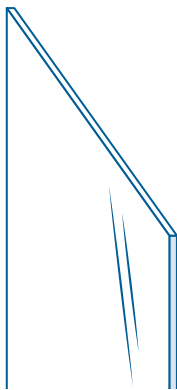

StyleLite Sheet

StyleLite Sheet is manufactured from high quality acrylic-capped ABS, and features reverse-side tread for superior bonding. StyleLite Sheet is sold for laminator's use only – it is provided ready for manual or machine lamination onto a variety of substrates.

Product	Sheet Size	Region	Weight	Finish
StyleLite Sheet	2440 × 1220 × 1mm	Global	1kg/m ²	High Gloss or Velvet
StyleLite Sheet	3000 × 1220 × 1mm	Global	1kg/m ²	High Gloss or Velvet
StyleLite Sheet	2440 × 1220 × 0.8mm	Global	0.8kg/m ²	High Gloss or Velvet
StyleLite Sheet	97" × 48.5" × 3/64"	USA	0.2lb/ft ²	High Gloss or Velvet

Edge Finishing

Color matched Edge Band rolls are available for StyleLite High Gloss and Velvet Panel products.

EGR has partnered with a variety of global edge finishing specialists to create an extensive range. All StyleLite compatible Edge Band is of premium quality and offer high resistance to heat, abrasion, impact and color fade.

StyleLite Edge Band is available in two options – **Standard** and **Fusion**.

Standard Edge Band

Color-matched Standard Edge Band is pre-primed ready for installation using EVA hot melt or PUR edge banding machinery.

Panel Type	Dimensions
Standard Edge Band for High Gloss or Velvet Panels	23mm × 1mm (100m roll)

Fusion Edge Band

Fusion Edge Band allows a seamless color matched functional layer to bond to the board using hot air or laser equipped machinery. Fusion Edge Band is available in selected colors only.

Panel Type	Dimensions
Fusion Edge Band for High Gloss or Velvet Panels	23mm × 1.2mm (100m roll)



Warning

Do not use PVC edge banding, solvent based adhesives or aggressive solvent based cleaners at any time.

Edge Band Technical Notes

Best results will be achieved using the following practices:

- CNC machining the panel edge or using an edge bander with pre-milling function.
- Leave protective film on panel in place at all times.
- Set trimming and scrapers to flush with surface of the StyleLite face, do not leave a lip.
- If there is glue overrun on the face, it can be removed using a microfibre cloth dampened with mineral turpentine, use sparingly and avoid excessive rubbing.
- If manual scraping or finishing is required, take care to avoid gouging the face of the panel.

EVA Hot Melt Adhesive

- Use white adhesive on white panels and transparent on dark panels.
- Using natural honey color adhesive will not deliver the best visual result.

PUR Polyurethane Adhesive

- Suitable for all colors and will deliver a highly moisture resistant panel.

Hinge Recommendations

When using StyleLite panels for door installations, ensure the appropriate amount of hinges are used to deliver a professional result.

Door Height	Number of Hinges
Up to 800mm [Up to 31"]	2 hinges
800 to 1300mm [31" to 51"]	3 hinges
1300 to 1800mm [51" to 70"]	4 hinges
1800 to 2100mm [51" to 82"]	5 hinges
2100 to 2440mm [82" to 97"]	6 hinges

- Always test hinge boring tools to ensure a clean cut is achieved.
- Best results will be achieved by drilling or boring through a thin MDF sacrificial block.
- Only bore the required amount of your hinge hardware.



Warning

**DO NOT REMOVE
PROTECTIVE
FILM UNTIL FINAL
INSTALLATION IS
COMPLETE**

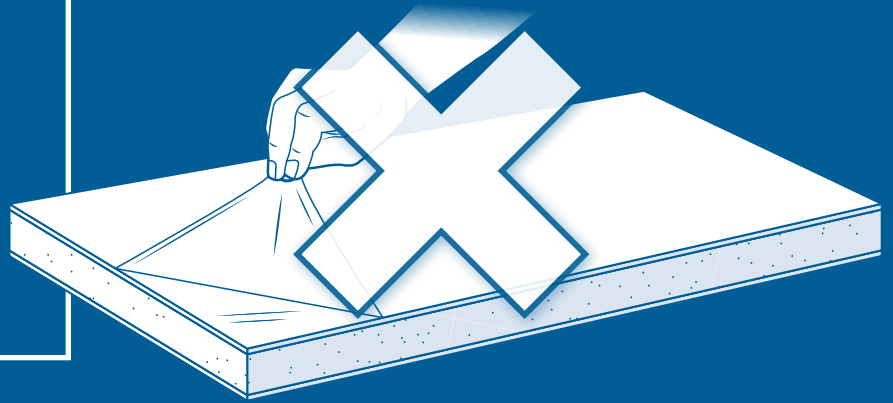

Things to Consider

- ▶ Adequate fixing should be provided at no greater than 400mm [15"] centres.
- ▶ We recommend an air gap of 6mm [¼"] adjacent to ovens and other heat sources.
- ▶ Do not over tighten handles as it may cause an unsightly dip in the high gloss surface.
- ▶ StyleLite achieves maximum hardness a few days after the removal of the protective film. This process can be accelerated with a light polish.
- ▶ Metallic colors are directional. Take note of the arrows on the protective film. All metallic panels should be assembled/installed with the arrows in one direction to avoid apparent shade or color variation.

Storage and Handling

StyleLite finished panels can be stored horizontally or vertically but should be well supported at all times.

- ▶ Do not store panels outside.
- ▶ Do not store or transport panels in direct sunlight.
- ▶ Avoid sliding the panels on the outer face surface.
- ▶ It is recommended that the panels are stored horizontally and supported at no more than 700mm [28"] from centres and 200mm [8"] from the ends to prevent the risk of warpage. All bearers should be of equal thickness and quality.
- ▶ Panels should be stored in well-ventilated and dry conditions.
- ▶ Cover boards should be placed on the top and bottom of stacked panels to provide protection and reduce the effects of environmental changes.

CORRECT STORAGE METHOD

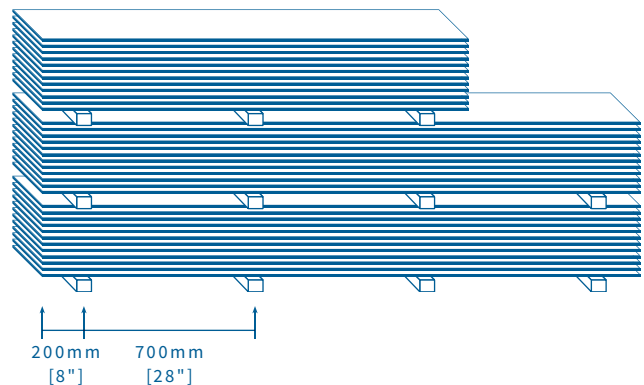

Machining Guide

Routering

Router cutting is the preferred method for cutting a StyleLite panel.

- ▶ Router cut using a feed rate of 10 to 15 metres per minute with a spindle speed of 20,000rpm.
- ▶ Solid carbide router cutters will deliver the best finish.
- ▶ Twin flute compression cutters are ideal as they minimise the chance of chipping at the edge and eliminate any feathering of the masking material on either side of the sheet.

Saw Cutting

- ▶ Use very sharp carbide tipped blades with 3 to 5 teeth per centimetre.
- ▶ We recommend using a 300mm diameter blade at a speed of 3200rpm for best results. Results may vary depending on your equipment.

Band saw

Band saws can be used to cut curves however a secondary finishing operation will be required.

Drilling

- ▶ Drilling can be done using high speed steel or carbide tipped drills.
- ▶ Best results will be achieved using drills with a tip angle of 110 to 130°.
- ▶ Use slow to medium speeds to avoid overheating the material.

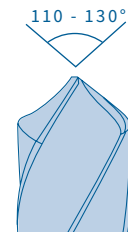
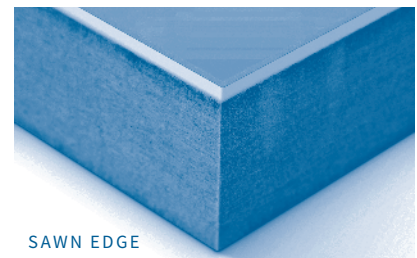
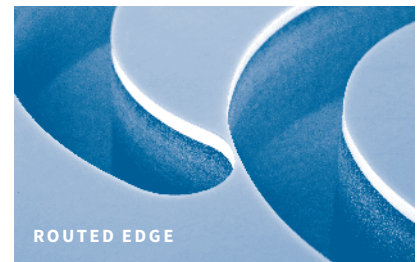

DRILL BIT 110 - 130°

Cleaning Do's and Don'ts

StyleLite products can be cleaned simply using a wet microfibre cloth or chamois with non-abrasive soap.

Do Use	Don't Use
✓ Clean wet microfibre cloth	✗ Paper towel
✓ Clean wet chamois	✗ Dry wipe at any time
✓ Novus No. 1 polish used often	✗ Brushes, scourers or scrapers
✓ Non abrasive soap and detergent	✗ Abrasive cleaners
✓ Warm water	✗ Thinners or Methylated Spirits

Scratch Repair

The StyleLite surface becomes more scratch resistant over the first few days after the removal of the protective film.

This process can be accelerated by lightly polishing the StyleLite surface immediately after the masking film is removed using Novus® No. 1 or Plexus® plastic polishes with a clean microfibre cloth.

 Please Note	The repair advice below applies only to StyleLite High Gloss products.
--	--

General Cleaning

Apply Novus® No. 1 Plastic Polish, Plexus® Plastic Polish or warm soapy water and wipe using a clean microfibre, soft cloth or damp chamois.

Removing Marks and Light Scratches

Apply Novus® No. 2 or a good quality liquid polish (e.g. 3M™ Finesse-It™ II, Kitten® Polishing Wax) and using a damp, clean microfibre or soft cloth, polish in a circular pattern. Then remove polish using General Cleaning procedure above.

Removing Heavier Scratches

Apply Novus® No. 3 or a good quality fine compound polish (e.g. 3M™ Perfect-It™ III) and using a damp, clean microfibre or soft cloth, polish in back and forth motion at right angles to visible scratches. Then use Removing Marks and Light Scratches procedure, then General Cleaning procedure above.

Ensure all polish residues are removed completely from the StyleLite surface. Low speed electric buffing can also be used to repair marks and scratches.

StyleLite Sheet Lamination Guide

StyleLite Sheet is an acrylic-capped ABS decorative sheet suitable for lamination onto a variety of substrates.

Lamination Materials and Process

StyleLite – 1.0mm for auto lamination.

Substrate – use select grade smooth sanded moisture-resistant MDF 16mm or thicker. A 240 grit sanded finish will provide the best finish results.

Backing panel – for single sided applications using unfinished MDF, adhere 0.8mm thick cabinet liner, or 0.8mm backing HIPS liner to rear surface of the substrate.

Hand Lamination – Water based EVA, liquid PUR'S and water based contacts are suitable. Apply with a roller or notched trowel to achieve even spread of adhesive.

Automated Lamination – PUR reactive hotmelt and water based EVA systems are suitable. Using an even and light to moderate adhesive build, will achieve the optimum visual appearance.

Doors and Panels

StyleLite laminated to MDF is for interior vertical applications only. A maximum finished panel size of 3000mm x 1200mm is recommended.

Pressing – Ensure StyleLite and substrate are clean and free of dirt and debris before lamination. Light to moderate cold press only. Hot pressing StyleLite may induce excessive bow in the finished panel. Block stack for 24 hours after pressing.

Curved Panels – StyleLite laminated panels can be formed into curves by curving the rear of the substrate, or curve the substrate first and then bond StyleLite to the substrate using a water based contact adhesive.

Lamination should only be completed from 15°C to 30°C ambient temperature. StyleLite, MDF and the liner should be stored under the same conditions to equalise for at least 12 hours prior to lamination.

Please Note

StyleLite laminated panels must always be suitably balanced on the reverse side of the substrate. Substrates can include MDF, HDF, Plywood or composite boards

Environmental Statement

StyleLite is a co-extruded, semi-rigid thermoplastic polymer sheet, which is intended as a lamination material suitable for bonding to a wide variety of substrates including CARB 2 MR MDF.

StyleLite consists of an ABS (acrylonitrile butadiene styrene) colored layer, which is permanently fused with a clear ultra high gloss Acrylic (Poly Methyl Methacrylate) top layer. StyleLite polymer sheet is an inert material and does not release any emissions to the environment during manufacture or in use. StyleLite is hygienic and does not promote bacterial growth or transmission.

All the color pigments used in StyleLite sheet do not contain heavy metals such as lead or cadmium.

StyleLite offers significant environmental advantages compared with other high gloss finishes. StyleLite manufacture produces no VOCs unlike two pack spray paint, and StyleLite can be recycled.

StyleLite recommended lamination adhesive systems include water based EVAs and PUR reactive hot melts. Neither system emits any volatiles during the lamination process or during the life of the finished board products.

StyleLite polymer sheet can be treated as ABS for recycling purposes and falls under the Styrene group of polymers. StyleLite can be removed from the substrate by passive immersion in water. StyleLite sheet can then be recycled using mechanical means by grinding and pelletising for reuse in a multitude of extruded or injection moulded products.

The StyleLite sheet material recycling process only consumes around 15% of the original energy consumption required to manufacture the initial sheet material.

StyleLite can be cleaned and maintained using warm soapy water, and does not require the use of harsh or volatile chemicals. StyleLite can be refinished in situ many times and will remain functional for many years.

StyleLite is wholly manufactured under the EGR Environmental Management System, which has been independently accredited to ISO 14001.



StyleLite 10 Year Indoor Warranty

StyleLite board is designed and manufactured as a decorative finish for indoor vertical surfaces applications only.

StyleLite is warranted for a period of 10 years from the date of sale of the Product by EGR to the original purchaser. EGR warrants the Product against faulty materials and processing subject to the terms, conditions and exclusions contained within this warranty document.

Should a valid warranty claim be made, EGR will provide replacement board and or a refund based on 100% of the original purchase price for the first 2 years and then a reducing value of the original purchase price of 10% per year after the first 2 years.

EGR warrants that the StyleLite board when installed and used according the EGR recommendations will be:

- compliant with the StyleLite Board specification for visible defects
- permanently bonded under normal indoor conditions
- free of color change from the original color supplied beyond a Delta E of 3.0 measured by reflection using a calibrated spectrophotometer
- flatness when correctly installed < 2.5 mm per 1000 mm in any direction
- of a gloss level above 85% measured at 60 degrees

In the event that a valid warranty claim is made to EGR's satisfaction, then EGR will, at its option, either repair the Product at EGR's premises or on site or provide replacement Product in a manner that EGR considers reasonable. If requested, EGR will compensate the purchaser to a reasonable labour charge, necessary for the repair or replacement of StyleLite board.

EGR will not be liable for any other consequential loss or damage whatsoever and however arising out of or in connection with the supply, performance or removal of the Product, including (but not limited to) any indirect or consequential loss including, without limitation, loss of profit, loss of revenue, loss of contract, loss of goodwill or increased cost of workings, even if due to the negligence of EGR or any of its approved distributors, employees or agents.

This warranty does not extend to fair wear and tear, delamination, warpage or surface damage of the Product, which in EGR's opinion directly or indirectly arise from or are due to:

- a. **Defects** are either insubstantial or insignificant; or
- b. **Physical abuse**, misuse, accidents, improper maintenance, normal 'wear and tear', scratches, scuffs, burns, stains, wipe marks on darker color surfaces; or
- c. **Variation in color**, pattern, shade of material against the sample material, display/s and/or printed illustrations due to general fading, discoloration or damage due to direct and indirect light (exposure to direct sunlight should be avoided); or
- d. **Water damage**, including damage from steam, excessive moisture or flooding;
- e. **Heat damage**, due to incorrect installation or use of the Product adjacent to ovens or hotplates or other high heat sources, including deformation, cracking, discoloration and scorching;
- f. **Heavy weight or impact**, placing heavy objects on the Product; applying substantial weight to the Product, including by standing, sitting or lying on the Product; or applying excessive impact to or mishandling the Product, including the impact caused by objects scraped along, thrown or dropped on to the Product's surface;
- g. **Chemical damage**, exposing the Product to acidic or corrosive materials, cosmetics and chemicals such as dyes, solvents, bleach, inks, acetone, denture cleaner and photo developing fluid;
- h. **Using inappropriate household cleaning products**, such as, abrasive powder and cream cleansers;
- i. **Failure to clean or maintain as recommended**
- j. **Structural design, installation or movement**, affecting where the Product has been installed, causing twisting, warping, bowing, cupping or shrinkage of the Product;

StyleLite 10 Year Indoor Warranty

- k. **Incorrect installation**, failure to follow the recommended fabrication and installation instructions and use of the Product;
- l. **Inappropriate use**, including use of the Product on, horizontal surfaces or outdoors;

For a warranty claim to be validated the affected board may be required to be returned to EGR for evaluation.

EGR reserves the right to undertake independent investigations into the cause of any warranty claim.

Warranty claims shall only be considered if the following conditions have been met:

1. It can be proven that the board has been used according to EGR recommendations for interior or commercial use.
2. EGR been made aware of the fault within seven days of receipt / inspection
3. The invoice from the supplier of the board can be produced. The invoice should show the name and address of the customer, the purchase date, the complete product description and the total quantity of the purchased board.

This warranty does not cover any other products used in conjunction to or installed with Stylelite.

This warranty only applies to the original purchaser and is non transferable.

This warranty document and other statements contained in this document or other documents given to you do not exclude, restrict or modify the application of any term implied into this warranty by statute, provided that (to the extent any statutory provision permits EGR to limit its liability for a breach of an implied condition or warranty), EGR's liability for such breach is limited to the payment of the cost of replacing the Product or acquiring an equivalent Product or repairing the Product.

The obligations of EGR under this warranty are limited to those set out and this warranty is expressly instead of all other warranties, express or implied, including any implied warranty of merchantability or fitness for a particular purpose and notwithstanding any course of dealing between the parties or custom and usage in the trade to the contrary.

This warranty becomes valid only when EGR has been paid in full for all product used.

This warranty applies only to Products sold in North America by EGR Inc or its approved Distributors.

Rev — V3 . 03.14.2016

StyleLite® Product Specifications

1/2

StyleLite laminated board complies with AS/NZS 4386.1 Domestic Kitchen Assemblies for Appearance, Flatness, Wood Substrate and the Adhesive Bonding System.

StyleLite Sheet Properties

Properties	Specification – High Gloss Sheet	Specification – Velvet Sheet	Test Method
Specific Gravity	1:09	1:09	ASTM D792
Water Absorption	<0.5%	<0.5%	ASTM D570
Surface Hardness	3H - 4H	5H	Pencil Hardness
Heat Distortion Temperature	85°C [185°F]	85° C [185° F]	ASTM D648
Service Temperature	70°C [158°F]	70° C [158° F]	Continuous
Burning Resistance	94HB	94HB	UL 94
Gloss Level	90GU	<20GU	Viewed at 60°
Mass 1mm	1.08kg/m ² [0.22 lbs/f2]	1.08kg/m ² [0.22 lbs/f2]	n/a
Surface Energy Rear	50	50	Dyne
Bond Strength	100N (25 Nm)	100N (25 Nm)	AS/ NZS 4266.28
Surface Soundness	1.25 MPa (0.9 MPa min)	1.25 MPa (0.9 MPa min)	AS/NZS 4266.7
Abrasion Resistance	< 1.0% loss of gloss	< 1.0% loss of gloss	500 cycles
Stain Resistance	No effect	No effect	AS/NZS 4266.25
Steam Resistance	No change after 30 minutes	No change after 30 minutes	AS/NZS 4266.23
Cracking Resistance	No effect	No effect	AS/NZS4266.24
Dry Heat Resistance	No loss of gloss or color change	No loss of gloss or color change	AS/NZS 4266.26

Textured Backing Sheet Properties

Properties	Test method ISO	Test method ASTM	Value ISO	Value ASTM
Tensile stress at yield/at break	527	D 638	27 MPa	26 MPa
Ball Indentation Hardness – H132/30, H 358/30	2039-1	-	85	-
Temp. of deflection under load – 1.8 MPa/HDT A	75	-	80°C [176°F]	80°C [176°F]
Specular Gloss (smooth surface; DIN 67530)	-	-	35%	-
Density	1183	-	1.05g/cm ³	-

StyleLite® Product Specifications

2/2

StyleLite laminated board complies with AS/NZS 4386.1 Domestic Kitchen Assemblies for Appearance, Flatness, Wood Substrate and the Adhesive Bonding System.

StyleLite Panel Properties

Properties	Specification	Test Method
Panel Length	-2 +10mm	Steel tape
Panel Width	-2 +5m	Steel tape
Panel Diagonal	< 3mm	Steel tape
Panel Thickness	+/- 0.5mm	Micrometer
Panel Mass	+/- 5.0%	Calibrated scale
Panel Edges	Face material +/- 2mm from the finished edge of the MDF core. Face and core edges must be parallel to +/- 1mm over the length of the edge.	Steel rule
Useable Surface	The useable surface of the panel will meet or exceed the program size offered, i.e. 2400 x 1200mm of useable area being the most common.	Steel rule
Face Bonding	100% fibre split	Cleavage peel
Flatness	< 2.5mm/1000mm in any direction	Steel tape
Solid Colors	Delta E 1.5 reflected	TS - 075
Metallic Colors	Delta E 2.0 reflected	TS - 075
Woodgrains	Visual match to master	Controlled master
Surface quality for panel face area up to 3.5m ² <small>Specks, dimples or raised sections will not be grouped closer than 100mm</small>	6 Specks <0.5mm; 6 dimples or raised section <3mm; No obvious die or flow lines; No scratches or repeat marks; No pin holes >0.2mm	Visual assessment in moderate interior lighting Board viewed in a vertical condition from a distance of 1000mm.
Surface quality for board back surface	No obvious die or flow lines; No scratches; No repeat marks	As above
Masking	No wrinkles or lifting at the edges, sound adhesion across the face area	Visual
Packaging	Suitable cover board top and bottom with four bearers and heavy duty PE straps. Cell air between each sheet, corner protection fitted and pack fully PE wrapped.	Work instruction
Batch Traceability	Face side masking printed with date of lamination	Process control plan

Metallic and woodgrains can vary in color from batch to batch and individual end use projects should be manufactured from the same batch.

StyleLite[®]

EGR

© Copyright 2017 / Patent Pending
Oakmoore Pty Ltd trading as EGR.
0102/1502 USA (V5 - 271117)